

Control for Suction Plants STW84V

with integrated control for dedusting of filters and volume flow

STW84V

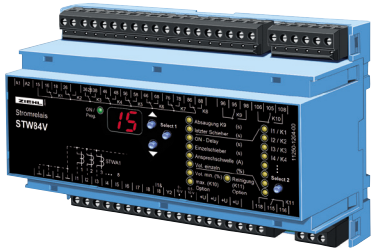

- Part numbers:**
- STW84V **S225522**
 - ER8 **T224388**

The basic function of the device is to detect whether a current is flowing in the supply line of one of several woodworking machines. If a current flow is detected, the device opens a valve on the machine's suction channel. At the same time, the extraction system is switched on. When a machine is switched off, the device closes the associated valve with a delay. If the last machine is switched off, the extraction system also stops after a delay.

The current relay STW84V monitors up to 8 alternating current sets on current flow yes/no. The inputs can analyse signals of current transformers type STWA1 or of potential-free contacts. For controlling of great dedusting plants several relays can be combined.

Applications: Controlling of dedusting plants in the timber and plastic processing industry according to the technical rules for dangerous materials TRGS 553. The central suction is switched on, as soon as any machine is put into operation. According slide valves in the suction ducts of the individual machines are opened. In addition, cleaning of a filter (vibration) and a cellular wheel/discharge can be controlled, an external cleaning (with compressed air) can be started or exceeding of max. volume flow can be reported.

The analog output 0...10 V can control a frequency-converter at the motor of the ventilator and thus optimize performance and save energy.

Description:

- Monitoring of 8 machines (STWA1 or contact)
- input for "open all slide valves"
- 8 relays (with change-over contacts) for slide valves
- 1 relay for control ventilator
- 1 relay for filter-cleaning
- 1 relay for control of cellular wheel/discharge or report exceeding max. volume flow
- analog output for control of frequency-converter and combination of more STW
- terminals plugable
- Universal supply voltage AC/DC 24-270 V

Functions/adjustments:

- run-after last slide valve 0...99 s
- turn-off delay ventilator 0...99 s
- minimum volume flow 1...100%, (if necessary automatic opening of additional slide valves, beginning with K8)
- maximum volume flow 5...100%

Individually adjustable per channel:

- turn-on delay I1... I8: 0... 20 s
- turn-off delay relay K1...K8: 0... 99 s
- operating value I1...I8: app. 0.5... 5A
- volume flow of slide valves 1...100%

Combination of more STW:

Master-relay considers volume-flow of other relays for:

- control of ventilator (relay K9 and analog output 0-10 V)
- opening of additional slide valves
- adding time for filter-cleaning
- report of exceeding max. volume flow

Control of cleaning of filters:

The run time of the ventilator is added with consideration of the volume flow. The dedusting of the filters is started after achieving the programmed run time (only with switched off ventilation).

- time for addition: 0... 99 min.
- added time stored permanently even at loss of power (power failure or upon completion of work)
- delay before start of cleaning: 0... 990 s
- number of dedusting impulses: 0... 20
- impulse on-time: 1... 30 s
- impulse off-time: 1... 990 s
- time of continuous dedusting: 0... 990 s
- alternatively impulse shaking 0.1... 9.9 s (square)
- alternatively dedusting request (with running suction)
- input for external dedusting command
- controlling a cellular wheel / discharge during dedusting

Displays and operation:

- 7-segment-display for settings during programming, in operation display of the volume flow
- 8 LEDs for input/output selection and display of the active inputs/outputs
- 9 LEDs for function selection
- easy programming

Accessory: [Installation frame ER8 for panel mount](#)

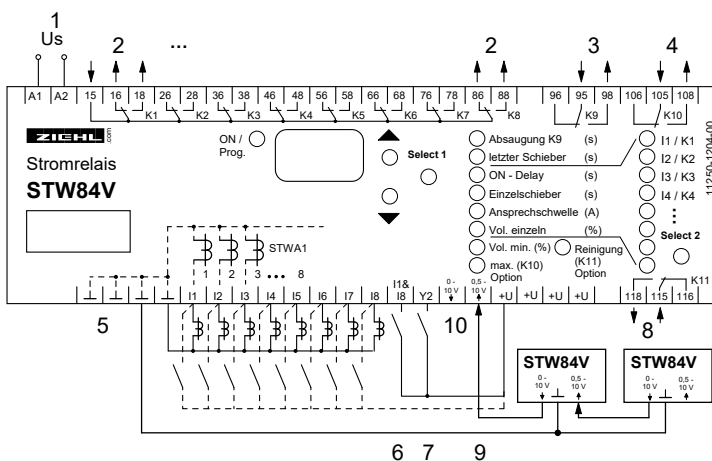

- | | |
|--|------------------------------|
| 1 power supply | 6 open all slide valves |
| 2 8 outputs for slide-valves (16, 26...86=close, 18, 28...88=open) | 7 external dedusting command |
| 3 suction ON | 8 dedusting/option |
| 4 max. volume-flow exceeded/option | 9 analog input |
| 5 inputs for current transformers STWA 1 | 10 control of suction power |

Technical Data STW84V

Power Supply	rated supply voltage U_s	AC/DC 24-270 V
	Voltage tolerance	+10...-15%
	Power consumption	< 12 VA
	Frequency	50/ 60 Hz
Relay output	Contact elements	11 change-over contacts (co)
	Type of contact (see with " general information " under relays)	type 3 max. 5 A/ 1250 VA
Test conditions	rated insulation voltage U_i	EN 61010 U_i 250 V
	Pollution degree	2
	rated impulse voltageelement	4000 V
	EMC - interference transmission	EN 61326-1 CISPR 11 class B
	EMC - interference resistance	EN 61326-1 (industrial surrounding)
	rated ambient temperature range	-20°C...+45°C
Voltage output +U		DC 17-21 V
		max. 120 mA at $U_s = 230$ V (max. 8 Current sensors S1) max. 10 mA at $U_s = 24$ V (0 sensors S1)
Inputs		1..8 STWA 1, floating contact or AC/DC 24 V, STWA 1 H or current-sensor S1
	Overload cap. continuous/max.10s	100 A/300 A
	Current overload capacity	ca.15 k Ω
	Operating value	adjustable 0.5... 5 A
	Tolerance	\pm 20%
Command inputs	Y2, external dedusting command	+ DC 24 V
	I1&I8, command all valves open internal resistance of inputs	+ DC 24 V approx.15 k Ω
Housing	Design / Installation Frame	V8 / Front mounting kit ER8, 8 TE
	Dimensions (h x w x d) mm	90 x 140 x 58 mm, mounting height 55 mm
	Wire connections	1 x 1.5 mm ² for each pole
	Installation position	any
	Attachment	on 35 mm DIN rail or M4 screws
	Housing protection	IP 30
	Terminal protection	IP 20
	Vibration resistance	1 mm 25 cycles per second / 10 g 25 - 100 cycles per second of
	Shock resistance	10 g 20 ms 20 g 4 ms
	Weight	approx. 350g